

# PERFORMANCE OF ABR FLOW CONTROL SCHEMES UNDER VARYING NETWORK CONDITIONS WITH TRANSIENT ANALYSIS

YIWEI THOMAS HOU

*Department of Electrical Engineering, Polytechnic University,  
Brooklyn, NY 11201, USA*

NANYING YIN

*Bay Networks, Inc., Billerica, MA 01821, USA*

SHIVENDRA S. PANWAR

*Department of Electrical Engineering, Polytechnic University,  
Brooklyn, NY 11201, USA*

This paper considers fundamental performance issues of closed-loop traffic management for ABR service. ABR service is designed to utilize network resource efficiently by dynamically adjusting each connection's transmission rate. ABR flow control protocols attempt to achieve this objective by estimating available network bandwidth and convey this information to the source. However, it is not clear how such flow control protocols will perform under varying network operating conditions. This paper presents performance results for ABR flow control schemes under time-varying available network bandwidth. We show the effective frequency range under which an ABR traffic management objective can be met. Our results demonstrate the limitations of ABR flow control protocols and offer practical guidelines for the implementation of ABR flow control algorithms.

## 1 Introduction

The Available Bit Rate (ABR) service defined by the ATM Forum<sup>1</sup> supports applications that allow the ATM source end system to adjust the information transfer rate based on the bandwidth availability in the network. Such applications include LAN interconnect, file transfer, Frame Relay, etc. By the traffic management specifications,<sup>1</sup> on the establishment of an ABR connection, the user shall specify to the network both a maximum bandwidth and a minimum required bandwidth, designated as Peak Cell Rate (PCR) and Minimum Cell Rate (MCR), respectively, for the requested connection. The source starts to transmit at an Initial Cell Rate (ICR), which is greater than or equal to MCR, and may adjust its rate based on congestion and bandwidth information from the network.

A generic closed-loop rate-based congestion control mechanism for ABR service is shown in Fig. 1. Resource Management (RM) cells are inserted periodically among ATM data cells to convey network congestion and available

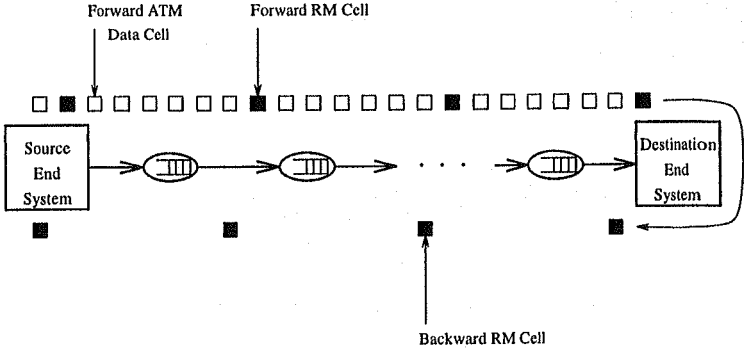

Figure 1: Closed-loop flow control for an ABR connection.

bandwidth information to the source. RM cells contain important information such as the source's Allowed Cell Rate (ACR) (called Current Cell Rate (CCR) in the RM cell's field), Minimum Cell Rate (MCR) requirement, Explicit Rate (ER), Congestion Indication (CI) bit and No Increase (NI) bit. A transit node and Destination End System (DES) may set the ER field, CI and NI bits in RM cells. All RM cells of an ABR virtual connection are turned back towards its source after arriving at the destination. Upon receiving a backward RM cell, the source adjusts its ACR accordingly.

After the traffic management specification<sup>1</sup> was completed, network equipment vendors are working on the implementation of ABR. But it is extremely important to understand how and under what conditions ABR works. This paper investigates the properties of rate-based ABR flow control schemes. Both binary and Explicit-Rate (ER) based flow control algorithms are examined. Our objective here is *not* presenting a better ABR flow control algorithm, but rather to show the operating frequency range for a class of flow control algorithms. Here, "frequency" is a generic term referring to the variation of network operating conditions, e.g. the number of active ABR connections and the variation of the available bandwidth along traversing links. Our paper contributes by offering insights on the properties and limitations of ABR flow control algorithms.

The remainder of this paper is organized as follows. Section 2 examines and defines both binary and ER traffic management schemes. The performance results for these algorithms are presented in Section 3 with discussion. Section 4 presents analytical results. Section 5 concludes this paper.

## 2 ABR Flow Control Schemes

There are different approaches and extensive studies on closed-loop rate-based traffic management<sup>3,5,10,12,14,15,16</sup>. These proposals fall into two broad categories, “binary feedback” congestion indication<sup>3,12,14,16</sup> and “explicit rate setting” schemes<sup>5,10,15</sup>. For simplicity, we refer them as binary and ER schemes, respectively. For binary schemes, a single bit feedback from the network is used to indicate congestion. For ER schemes, an estimated available bandwidth information is contained in the feedback RM cell to inform the SES. Binary schemes preserve backward compatibility with EFCI-marking switches,<sup>2</sup> while the newer ER-based schemes promise higher efficiency and stability with additional implementation cost.

There are extensive control parameters involved in a closed-loop traffic management mechanism. We list the parameters in the Appendix at the end of the paper.

### 2.1 Binary Mode

In a manner consistent with the ABR specifications, we define the binary scheme as follows.

#### Source behavior:

1. The initial ACR is set to ICR.
2. A source transmits an RM cell for every  $N_{rm}$  ATM data cells transmitted. The CI bit in an RM cell is set to 0 and the CCR field is set to ACR.
3. Upon receiving a backward RM cell, the new ACR is set to:

$$\text{ACR} := \begin{cases} \min\{(\text{ACR} + N_{rm} \cdot \text{AIR}), \text{PCR}\} & \text{if CI} = 0, \\ \max\{(\text{ACR} \cdot \text{RDF}), \text{MCR}\} & \text{if CI} = 1. \end{cases}$$

**Destination behavior:** Upon receiving a forward RM cell from source, the destination simply returns it in the backward direction to the source.

#### Switch behavior:

1. The forward RM cells carry ACR information and update the ACR table at the switch for each VC.
2. The switch sets the CI bit of backward RM cells according to the following rule.

When the node queue length exceeds the threshold  $QT$ , the switch selectively marks  $CI=1$  on those backward RM cells with  $CCR$  greater than the average  $CCR$ .<sup>a</sup>

When the bottleneck link queue length exceeds  $DQT$ , the switch marks all backward RM cells with  $CI=1$ .

## 2.2 ER Mode

An ER scheme is a distributed flow control protocol implemented at each ATM switch. It estimates available bandwidth at a switch for each ABR virtual connection through distributed and asynchronous iterations and shares information between the ABR source and switches through traversing RM cells.

### The Ideal Case: Each Node Has Global Information

In the idealized situation where each node has global knowledge of available network bandwidth and the number of active virtual connections, the switch can calculate the rate for each VC. Here, the only limitation is the round trip time (RTT) between source and switch needed to convey rate information to the source. This gives us the theoretical limit for any ABR flow control scheme.

### Distributed ER Schemes

In the practical scenario where each node does not have the global knowledge of network operating conditions, an estimate of available bandwidth for a VC is required. The "Intelligent Marking" technique proposed by Siu and Tzeng<sup>15</sup> uses a variable at each node, called the Mean Allowed Cell Rate (MACR), to estimate the optimal cell rate at which a VC can transmit based on the congestion state at the switch. This simple scheme avoids the use of per-VC accounting while achieving satisfactory performance in terms of fairness and link utilization.

In the following, we define the Intelligent Marking ER scheme. In Section 3, we present performance results of this scheme under various bandwidth operating frequencies. As we will see, the Intelligent Marking ER scheme is only effective in the "low frequency" range, which is determined by the transient convergence time of the switch variable (MACR) to reach steady state, a time scale that is much larger than the round trip time between source and switch.

The SES and DES behavior of the Intelligent Marking ER scheme is essentially the same as that of a binary scheme, except that the SES adjusts its

---

<sup>a</sup>This is the so called "relative rate marking" and helps to solve the "beatdown" problem.<sup>1</sup>

cell rate using the ER field (rather than the CI bit) upon receiving backward RM cells. The main feature of an ER scheme is characterized by the switch algorithm used to estimate the available bandwidth for each VC.

#### Source behavior:

1. The initial ACR is set to ICR.
2. A source transmits an RM cell for every  $N_{rm}$  data cells transmitted. The ER field in an RM cell is set to PCR and the CCR field is set to ACR.
3. Upon receiving a backward RM cell, the new ACR is set to:

$$ACR := \max\{\min\{(ACR + N_{rm} \cdot AIR), ER, PCR\}, MCR\}$$

**Destination behavior:** Upon receiving a forward RM cell from source, the destination simply returns it in the backward direction to the source.

#### Switch behavior:

1. A forward RM cell updates MACR at the switch according to the flow chart in Fig. 2.
2. The switch sets the ER field of a backward RM cell according to the flow chart in Fig. 3.

Note that our definition for “switch congestion” in Figs. 2 and 3 is a time-based congestion detection, which is able to detect congestion faster than a simple threshold. Here, congestion in the switch is detected by the change of queue length after processing, say,  $K$  cells. In our implementation, we use one switch variable that records the queue length seen by the last arriving RM cell. If the queue length seen by a newly arrived RM cell is greater than this variable, i.e. queue length increases between consecutive arriving RM cells, the switch is said to be in congestion. Both this variable and the switch’s congestion state are updated by each newly arrived RM cell.

### 3 The Performance of ABR Flow Control Schemes

In this section, we present simulation results demonstrating the performance of ABR flow control algorithms defined in Section 2 under various frequency ranges. Our objective is to identify the frequency range under which a scheme can operate effectively. We choose to use a persistent source (i.e. it always has data to send) under time-varying internodal available bandwidth. Although,

in practice, most ABR sources are not persistent, but rather bursty on/off in nature, the effective frequency range for a particular flow control scheme can be most clearly illustrated by using a persistent source and time-varying bandwidth. Moreover, by studying the performance of a scheme for a persistent source under time-varying available bandwidth, one can imply similar results for a bursty source (i.e. source traffic profile characterizable in frequency domain<sup>11</sup>) under constant available bandwidth.

### 3.1 The Ideal Case: Each Node Has Global Information

This is the ideal case that we discussed in Section 2.2. After an SES starts to transmit cells, it takes  $RTT_{SD}$  for the first RM cell to return back to the source. This RM cell contains the exact rate at which the source should transmit. After receiving the first backward RM cell, the backward RM cells return periodically to the source and the feedback information from the switch is only delayed by the propagation time between the switch and SES,  $\tau_{SX}$  or  $\frac{1}{2}RTT_{SX}$  (note that the switch sets the ER field in the *backward* RM cell).

Fig. 4 shows the “low frequency” case for an ABR connection. We call it “low frequency” since the available BW variation half period  $\frac{T}{2}$  ( $= 100$  ms) is much greater than  $RTT_{SX}$  ( $= 5$  ms). The ACR at source and CCR at the node are delayed waveforms of available BW by  $\frac{1}{2}RTT_{SX}$  and  $RTT_{SX}$ , respectively. Fig. 5 shows the instantaneous load, defined as,

$$\text{Load} \stackrel{\text{def}}{=} \frac{\text{CCR at node}}{\text{available BW}}$$

and queue length for the same simulation run. We see that except for short periods (equal to  $RTT_{SX}$ ) which peak and drop at the points when available BW varies, the load is 1 most of time.

Figs. 6 and 7 show the performance of ER scheme when the available BW’s variation half period  $\frac{T}{2}$  ( $= 7.5$  ms) is close to  $RTT_{SX}$ . We see that CCR at the node no longer can keep up with the available BW variation and the instantaneous load differs from 1 most of the time. Here, even the ideal ER scheme does not work.

We conclude that under the ideal case where the internodal link has complete knowledge of available BW, the operating frequency range for an ER scheme is limited by  $RTT_{SX}$  and should satisfy

$$f_{\text{effective}} \ll \frac{1}{RTT_{SX}} \quad (1)$$

### 3.2 The Intelligent Marking ER Scheme

This is the ER scheme we discussed in Section 2.2. The parameters used in our simulation are listed below.

$PCR = 155$ Mbps	$DQT = 1000$ cells	$AV = 0.25$
$ICR = 10$ Mbps	$QT = 500$ cells	$MRF = 0.5$
$MCR = 0.155$ Mbps	$\tau_{SX} = 1$ ms	$ERF = \frac{31}{32}$
$AIR = 0.03125$ Mbps	$\tau_{XD} = 1$ ms	$N_{rm} = 32$

Fig. 8 shows the CCR at a node and the available bandwidth (BW) for one VC in the low frequency case with  $\frac{T}{2} = 100$  ms and  $RTT_{SX} = 2$  ms.<sup>b</sup> The ramp-up time as illustrated in Fig. 8 is usually a much larger time period than the round trip time. After reaching steady state, the CCR at the node follows the available BW quite closely. Fig. 9 shows the load and queue length for the same simulation run. We see that except for peaks and drops of load at BW transition points, the load is close to 1 most of the time. This shows that the Intelligent Marking ER scheme works fairly well in the low frequency case.

Figs. 10 and 11 show the performance when the available BW variation period decreases to  $\frac{T}{2} = 10$  ms, which is still much greater than  $RTT_{SX}$  ( $= 2$  ms). We see that such a BW variation is already too rapid for our ER scheme to operate effectively. This is due to the convergence time required for the MACR to reach a steady state whenever BW changes value. This convergence time for MACR is the fundamental limitation to the operating frequency of the Intelligent Marking ER scheme.

We conclude that the effective operating frequency range for the Intelligent Marking ER scheme should satisfy,

$$f_{\text{effective}} \ll \frac{1}{T_{\text{convergence}}} \quad (2)$$

where  $T_{\text{convergence}}$  is the convergence time for MACR to reach a new steady state when BW changes between values. In Section 4, we will perform analysis on the transient behavior of the Intelligent Marking ER scheme.

### 3.3 The Binary Scheme

We present simulation results for the binary scheme we defined in Section 2.1. The parameters used in our simulation are listed below.

---

<sup>b</sup>The first period of BW actually starts from  $t = 100$  ms in our simulation.

$PCR = 155$  Mbps  
 $ICR = 10$  Mbps  
 $MCR = 0.155$  Mbps  
 $AIR = 0.03125$  Mbps

$DQT = 1000$  cells  
 $QT = 350$  cells  
 $\tau_{SX} = 1$  ms  
 $\tau_{XD} = 1$  ms

$RDF = 0.99$   
 $N_{rm} = 32$

Ignoring those parameters used only for the ER scheme, the above parameters are essentially the same as those listed in Section 3.2 for the Intelligent Marking ER scheme.<sup>c</sup>

Figs. 12 and 13 show the performance of our binary scheme in the low frequency case with  $\frac{T}{2} = 100$  ms. Since the source only knows about the presence or absence of congestion, but does not know how much to increase or decrease its transmission rate, the CCR value oscillates around the optimal rate. In comparison with Figs. 8 and 9, it is obvious that the zig-zag nature of CCR under the binary scheme makes it less desirable than the ER scheme. This illustrates that the ER scheme outperforms the binary scheme in the low frequency case.

Figs. 14 and 15 show the performance of our binary scheme at a higher frequency range with  $\frac{T}{2} = 10$  ms. Here, we have more interesting results. In comparison with Figs. 10 and 11, the obvious advantage of ER scheme over binary scheme in low frequency case disappears. That is, when the variation frequency of available BW becomes sufficiently high, the elaborate Intelligent Marking ER scheme loses its accuracy and *may* not perform better than a simple binary bit setting mechanism.

### 3.4 Discussion

Based on our simulation results, we have the following observations on scheme effectiveness vs. frequency.<sup>d</sup> The ideal ER scheme is the most effective closed-loop congestion control. The Intelligent Marking ER scheme is better than binary scheme only at a very low frequency range ( $\ll T_{\text{convergence}}^{-1}$ ). Once over  $T_{\text{convergence}}^{-1}$ , the Intelligent Marking ER scheme loses its accuracy and does not seem to have obvious advantage over the binary scheme.

The operating frequency range for ER and binary feedback mechanisms were demonstrated above by using a persistent source under frequency varying bandwidth. In practice, the number of ABR VCs at a bottleneck internodal

<sup>c</sup>Since our binary scheme does not employ the elaborate time-based congestion detection algorithm used for ER scheme, Queue Threshold (QT=350 cells) is set to be smaller than that in Section 3.2 (500 cells) to make the binary scheme operate properly.

<sup>d</sup>The scheme effectiveness is a measure of: 1. How well the CCR can follow its available BW at node; and 2. The fluctuation of buffer occupancy (ideally, we want to keep the buffer content at a steady constant level, i.e., keep load equal to 1).



link varies with time as well as each ABR VC source profile (usually on/off). A simple expression showing the operating frequency is not obvious. However, it is expected that equivalent or similar results will hold. As an example, for the Intelligent Marking ER scheme, only when the on/off burstiness of each source as well as the number of VCs vary on a much larger time scale than  $T_{\text{convergence}}$ , will such a scheme operate effectively.

## 4 Transient Convergence Analysis

From the discussion in the previous section, we find that the convergence time of an ER scheme sets the limit of its effective frequency range. In this section, we analyze the transient behavior of the Intelligent Marking ER scheme.

### 4.1 Rise Time Analysis

Assuming the buffer is initially empty at the node, then the node is congestion free when available BW > ICR. Suppose that a source receives an RM cell at  $t$  and the next RM cell at  $t'$ . Then we have

$$ACR(t') = ACR(t) + N_{rm} \cdot AIR \quad (3)$$

Rearranging terms and divide both sides by  $t' - t$ ,

$$\frac{ACR(t') - ACR(t)}{t' - t} = \frac{N_{rm} \cdot AIR}{t' - t}$$

We approximate the above by the following continuous-time differential equation:

$$\frac{d}{dt}ACR(t) = \frac{N_{rm} \cdot AIR}{t' - t} \quad (4)$$

Ignoring cell transmission time at internodal link, an RM cell returned to the source at time  $t$  must be transmitted at time  $t - RTT_{SD}$  under a source cell rate of  $ACR(t - RTT_{SD})$ . According to the system definition of our ER scheme,  $N_{rm}$  cells were transmitted in the interval  $[t - RTT_{SD}, t' - RTT_{SD}]$ , i.e.

$$N_{rm} = \int_{t-RTT_{SD}}^{t'-RTT_{SD}} ACR(\tau) d\tau \quad (5)$$

Again, we approximate the above by letting

$$N_{rm} = ACR(t - RTT_{SD}) \cdot [(t' - RTT_{SD}) - (t - RTT_{SD})]$$

Table 1: Analytical and simulation results for ACR rise time at SES.

Available BW (Mbps)	Rise Time (ms)		
	Numerical Analysis	Exponential Estimate	Simulation
20	14.20	15.05	14.40
40	26.08	27.25	26.49
60	33.04	34.35	33.50
80	37.96	39.40	38.47
100	41.80	43.35	42.32

or

$$t' - t = \frac{N_{rm}}{ACR(t - RTT_{SD})} \quad (6)$$

Combining Eqs. (4) and (6), we have

$$\frac{d}{dt}ACR(t) = AIR \cdot ACR(t - RTT_{SD}) \quad \text{for } t > RTT_{SD}. \quad (7)$$

with  $ACR(t) = ICR$  for  $t \in [0, RTT_{SD})$  and  $ACR(RTT_{SD}) = ICR + N_{rm} \cdot AIR$ .

Eq. (7) is a delay-differential equation, whose exact closed-form solution involves contour integration and residual theorem and is difficult to obtain in general. A numerical solution of  $ACR(t)$  using a simple iterative procedure is given by Hou *et al.*<sup>9</sup>

While the above numerical solution is easy to obtain, it does not give us insight on the mathematical property of  $ACR(t)$ . We will approximate  $ACR(t)$  with an exponential. By using a fundamental lemma by Hale and Verduyn Lunel,<sup>6</sup> we obtain the following solution for  $ACR(t)$ .

$$ACR(t) = \frac{(ICR + N_{rm} \cdot AIR)}{(1 + AIR \cdot RTT_{SD})} \cdot \exp\left[\frac{AIR}{(1 + AIR \cdot RTT_{SD})} \cdot t\right] \quad (8)$$

for  $t > RTT_{SD}$ . The details are provided by Hou *et al.*<sup>9</sup>

To validate our estimates, we quantitatively compare our analytical results with simulations in Table 1. The parameter settings are the same as the simulation parameters in Section 3.2.

Fig. 16 illustrates the case for available BW = 100 Mbps shown in Table 1. Note that it is possible to reduce the response time for ACR from ICR to available BW by increasing AIR. But this will result in wider oscillation range.

for ACR once it reaches BW, which would undermine the effectiveness of our ER scheme.

Also shown in Fig. 16 is the MACR, which follows closely to the ACR at source. Unlike ACR, which keeps oscillating (in an attempt to increase cell rate should bandwidth become available from the network), the MACR stays close to  $BW_h$  once it reaches there. This is because the MACR can be increased only when the switch is congestion free *and* CCR is greater than MACR (see protocol in Fig. 2). Or equivalently, MACR can only be increased if

$$\text{MACR} < \text{CCR} < BW_h \quad (9)$$

Once MACR reaches  $BW_h$ , (9) will no longer be satisfied and MACR will stay at the available link  $BW_h$ , which is the desired optimal cell rate that an ABR VC should set.

#### 4.2 Decay Settling Time

The exact analysis of MACR behavior for our protocol when available BW decreases from  $BW_h$  to  $BW_l$  is very complicated. However, due to the scope of this paper, it is enough to show qualitatively that: 1) MACR will eventually settle down to  $BW_l$ ; and 2) the decay settling time is greater than  $RTT_{SX}$ .

Claim 2 above is obvious since it will take at least  $RTT_{SX}$  to make any necessary change of CCR at node when feedback information is marked on backward RM cells. If the difference between  $BW_h$  and  $BW_l$  is large, it is intuitive that such decay settling time will be much larger than  $RTT_{SX}$ .

To show that Claim 1 is true, we use similar arguments in Section 4.1. According to our ER protocol (Fig. 2), MACR can only be decreased when switch is in congestion (queue length is found to be increasing by an arriving RM cell at the node) *and* CCR is less than MACR. Or equivalently, MACR can only be decreased if

$$BW_l < \text{CCR} < \text{MACR} \quad (10)$$

As an example, Fig. 17 shows in detail of the simulation results in Figs. 8 and 9 at the bandwidth transition time. Segments A, B and C show the time intervals where (10) is satisfied. Also note that at the end of segments A, B and the entire segment D, there are major rate reductions ( $ER \leftarrow \min(ER, \text{MRF} \cdot \text{MACR})$ ) when the queue length is over DQT (1000 cells). Since CCR adjusts its rate dynamically based on our protocol, it will attempt to increase its rate beyond  $BW_l$ . Therefore, (10) is satisfied from time to time and MACR is decreased eventually down to  $BW_l$ . Once MACR reaches  $BW_l$ , (10) will no longer be satisfied. So MACR will settle down at  $BW_l$ , which is again the desired optimal cell rate an ABR VC should set.

## 5 Concluding Remarks

In this paper, we examined flow control schemes for ABR service and presented performance results for binary and ER schemes under time-varying network bandwidth. We have the following observations regarding the design of ABR flow control algorithms.

1. Any ABR scheme's operating frequency is constrained by the round trip time of feedback loop.
2. In practice, for a distributed ER scheme, its effective frequency is further limited by the transient convergence time of the algorithm from an initial condition to the final optimal rate.
3. The ER scheme performs better than the binary scheme under low frequency ( $< T_{\text{convergence}}^{-1}$ ). However, such advantage diminishes as inter-nodal link available BW's variation frequency increases.
4. At higher frequency range, there does not seem to be any clear advantage of the ER scheme over the binary scheme. Thus, the necessity of implementing ER algorithm (with additional cost) over simple binary algorithm at an ATM switch has to be carefully justified according to the actual network environment.

Our future work will focus on the mathematical development of an ER scheme's effectiveness in the frequency domain, which we hope will provide a common quantitative performance measure for current and emerging ABR flow control algorithms.

## Acknowledgments

This work is supported by a National Science Foundation Graduate Research Traineeship and by the New York State Center for Advanced Technology in Telecommunications at Polytechnic University, Brooklyn, NY, USA.

## Appendix: System Parameters

### Source End System

*PCR* Peak Cell Rate.

*MCR* Minimum Cell Rate.

*ACR* Allowed Cell Rate.

*ICR* Initial Cell Rate.

*AIR* Additive Increase Rate.

*RDF* Rate Decrease Factor.

$N_{rm}$  Number of cells between consecutive RM cells.

### **RM Cell Fields**

*CCR* Set to *ACR* by the source.

*ER* Explicit Rate; initially set to *PCR*.

*CI* Congestion Indicator; 0 = no congestion, 1 = congestion.

*NI* No Increase bit.

*DIR* Direction of RM cell; forward or backward.

### **Switch Parameter Settings**

*MACR* Mean *ACR*.

*QT* Queue Threshold; the low queue limit to determine congestion.

*DQT* Down Queue Threshold; the high queue limit to determine very congested.

*AV* Averaging factor; used by *MACR* to estimate optimal *ACR*.

*MRF* Major Reduction Factor.

*DPF* Down Pressure Factor.

*ERF* Explicit Rate Factor.

### **Other Parameters**

$\tau_{SX}$  Propagation delay between SES and bottleneck switch.

$\tau_{XD}$  Propagation delay between bottleneck switch and DES.

$RTT_{SD}$  Round Trip Time between SES and DES;  $RTT_{SD} = 2(\tau_{SX} + \tau_{XD})$ .

$RTT_{SX}$  Round Trip Time between SES and bottleneck switch;  $RTT_{SX} = 2\tau_{SX}$ .

$N_{VC}$  Number of ABR virtual connections.

## References

1. ATM Forum Technical Committee, "Traffic Management Specification - Version 4.0," *ATM Forum/95-0013R10*, Feb. 1996.
2. ATM Forum Inc., *ATM User Network Interface (UNI) Specification Version 3.1*, First Edition, Prentice-Hall, Inc., New Jersey, 1995.
3. A. W. Berger, F. Bonomi, and K. W. Fendick, "Proposal for backward congestion feedback at the ATM UNI," *ATM Forum Contribution, 93-839R1*, Sept. 1994.
4. R. Bellman and K. L. Cooke, *Differential-Difference Equations*, Academic Press, 1963.
5. A. Charny, D. D. Clark, and R. Jain, "Congestion Control with Explicit Rate Indication," *Proc. IEEE ICC '95*, pp.1954-1963, June 1995.
6. J. K. Hale and S. M. Verduyn Lunel, *Introduction to Functional Differential Equations*, Springer-Verlag New York Inc., 1993.
7. Y. T. Hou, N. Yin, and S. S. Panwar, "Effective Frequency Range of Rate-Based Closed-Loop Congestion Control for ABR Service," *Proc. IEEE ATM '96 Workshop*, August 25-27, 1996, San Francisco, CA.
8. Y. T. Hou, L. Tassiulas, and H. J. Chao, "Overview of Implementing ATM-Based Enterprise Local Area Network for Desktop Multimedia Computing," *IEEE Communications Magazine*, April 1996, pp.70-76.
9. Y. T. Hou, N. Yin, and S. S. Panwar, "On the Effectiveness of Closed-Loop Rate-Based Traffic Management Schemes for ABR Service in ATM Networks," *Tech. Report CATT 96-91*, Center for Advanced Technology in Telecommunications (CATT), Polytechnic University, Brooklyn, NY, April 11, 1996.
10. R. Jain, *et al.*, "ERICA Switch Algorithm: A Complete Description," *ATM Forum Contribution, 96-1172*, August 1996.
11. S.-Q. Li and C.-L. Hwang, "Queue Response to Input Correlation Functions: Continuous Spectral Analysis," *IEEE/ACM Trans. on Networking*, Vol.1, No.6, Dec. 1993, pp.678-692.
12. P. Newman, "Backward Explicit Congestion Notification for ATM Local Area Networks," *Proc. IEEE GLOBECOM '93*, pp.719-723, Dec. 1993.
13. H. Ohsaki, *et al.*, "Rate-Based Congestion Control for ATM Networks," *ACM SIGCOMM Computer Communication Review*, Vol.25, No.2, April 1995, pp.60-72.
14. K. K. Ramakrishnan and R. Jain, "A Binary Feedback Scheme for Congestion Avoidance in Computer Networks," *ACM Trans. on Computer Systems*, Vol.8, No.2, pp.158-181, May 1990.

15. K.-Y. Siu and H.-Y. Tzeng, "Intelligent Congestion Control for ABR Service in ATM Networks," *ACM SIGCOMM Computer Communication Review*, Vol.24, No.5, Oct. 1994.
16. N. Yin and M. G. Hluchyj, "On Closed-Loop Rate Control for ATM Cell Relay Networks," *Proc. IEEE INFOCOM '94*, pp.99-108, June 1994.

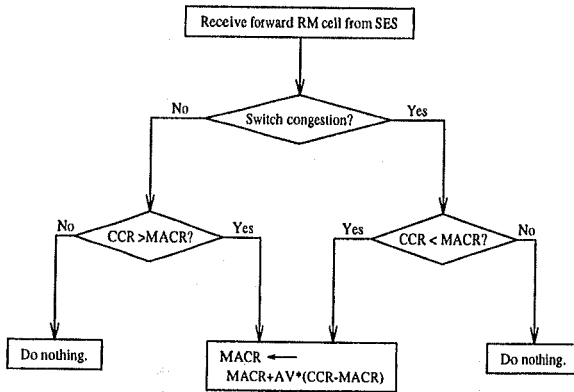

Figure 2: Switch behavior when receiving a forward RM cell.

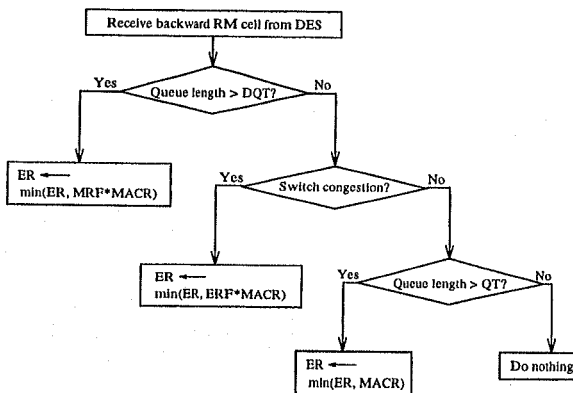

Figure 3: Switch behavior when receiving a backward RM cell.

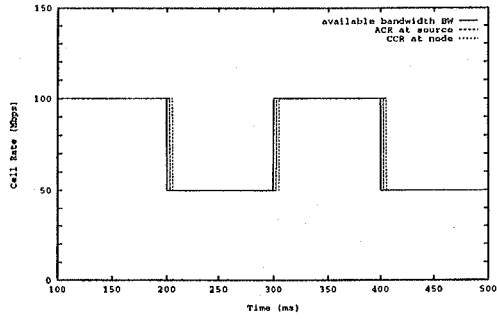

Figure 4: ACR at source, CCR at node, and available BW for the ideal ER scheme (low frequency).

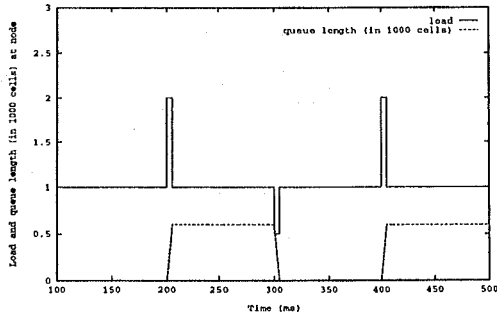

Figure 5: Traffic load and queue length for the ideal ER scheme (low frequency).

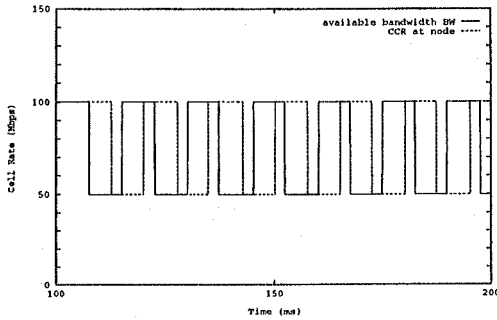

Figure 6: CCR at node and available link BW for the ideal ER scheme (high frequency).



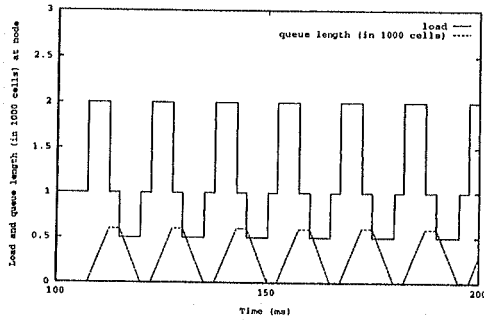

Figure 7: Traffic load and queue length for the ideal ER scheme (high frequency).

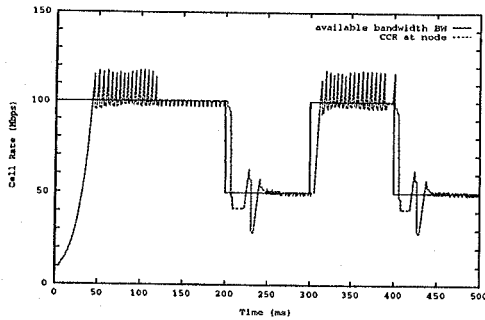

Figure 8: CCR at node and available link BW for the Intelligent Marking ER scheme (low frequency).

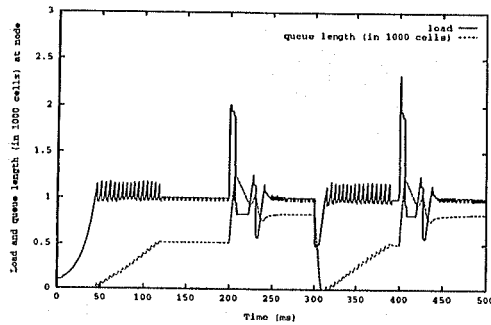

Figure 9: Traffic load and queue length for the Intelligent Marking ER scheme (low frequency).

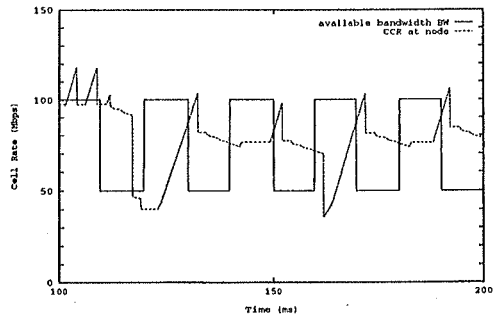

Figure 10: CCR at node and available link BW for the Intelligent Marking ER scheme (mid-frequency).

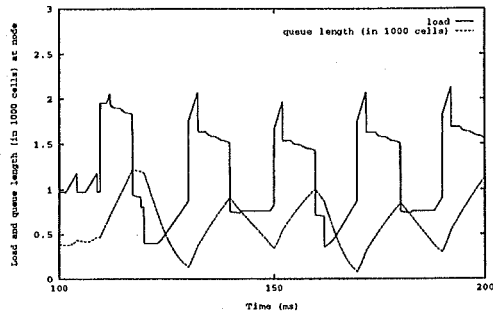

Figure 11: Traffic load and queue length for the Intelligent Marking ER scheme (mid-frequency).

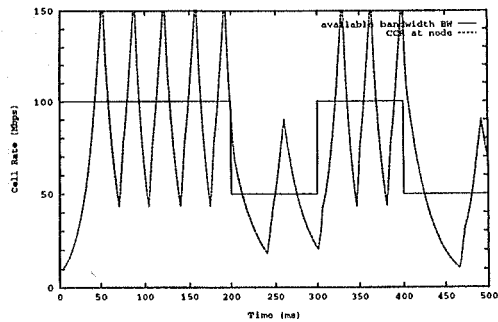

Figure 12: CCR at node and available link BW for the binary scheme (low frequency).

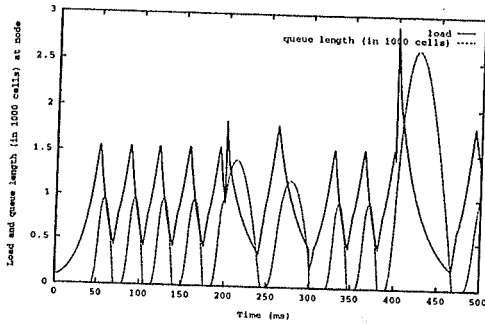

Figure 13: Traffic load and queue length for the binary scheme (low frequency).

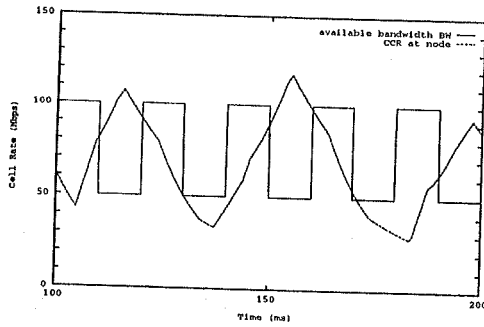

Figure 14: CCR at node and available link BW for the binary scheme (mid-frequency).

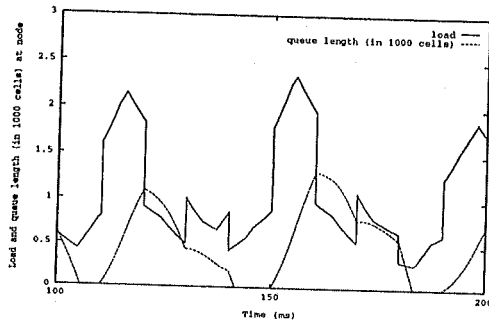

Figure 15: Traffic load and queue length for the binary scheme (mid-frequency).

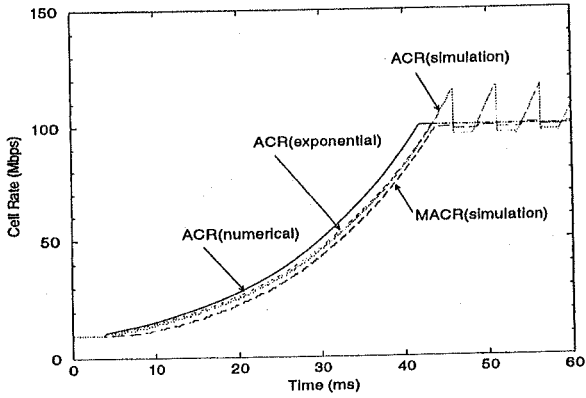

Figure 16: Transient rise behavior of ACR and MACR at SES.

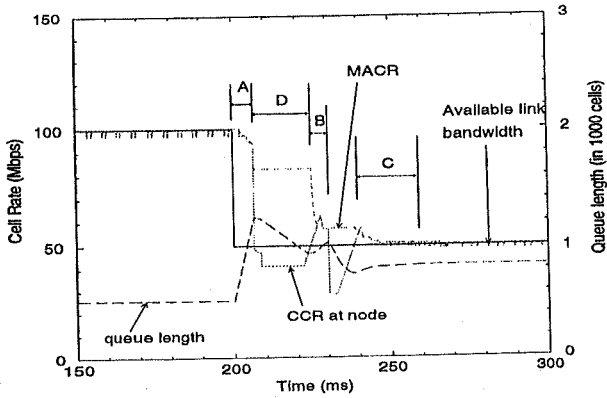

Figure 17: Transient decay behavior of ACR and MACR at SES.